

| Typ / Type : Z 400 E1 | | Art.-Nr. / Art.-No. : F05-40007 | |
|------------------------------|------------------------|--|---------|
| U | 230V (50Hz) | Δp _{fa} min | -- Pa |
| P ₁ | 0.83 kW | ΔI | -- % |
| I _N | 4.0 A | I _A / I _N | 2.0 |
| n | 1300 min ⁻¹ | | IP54 |
| C _{400V} | 16 μF | | 01.024 |
| t _R | 45 °C | | 46.0 kg |

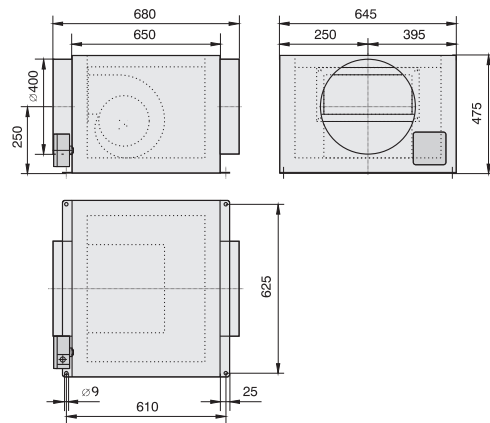

| LWA _{rel} A-bewertet bei V=0,5*V _{max} LWA _{rel} A-weighted at V=0,5*V _{max} | fM [Hz] | | | | | | |
|---|---------|-----|-----|----|----|----|----|
| | 125 | 250 | 500 | 1K | 2K | 4K | 8K |
| LWA ₂ [dB(A)] Gehäuse / casing | 51 | 53 | 47 | 41 | 37 | 31 | 26 |
| LWA ₅ [dB(A)] Ansaugseite / inlet side | 53 | 54 | 49 | 51 | 51 | 52 | 45 |
| LWA ₆ [dB(A)] Ausblasseite / outlet side | 62 | 63 | 66 | 70 | 68 | 68 | 61 |